

Motorized Platform Cart

ET300P2 · ET150P2



All-round Transportation and Distribution Assistant

300kg-Climbing Expert

Built-in gyroscope, vehicle self-sensing matching output power. Strong climbing power, smooth and safe downhill, Efficient handling frees up your hands.



Intelligent Safety

Featuring automotive grade sensors, 16 contact design, precise recognition, sensitive control, The vehicle can only be started in body-balance condition.



FOC Control Technology

All-round smooth and silky steering, quiet and energy-saving. It handles all kinds of roadblocks steadily, with plenty of power and no skidding.



Original Design -Patented Technology

Modular design for quick disassembly and assembly. Easy to carry and store.



Compatible With Different Flatbed Hand Trucks

Switch between cargo and cycling at your convenience.

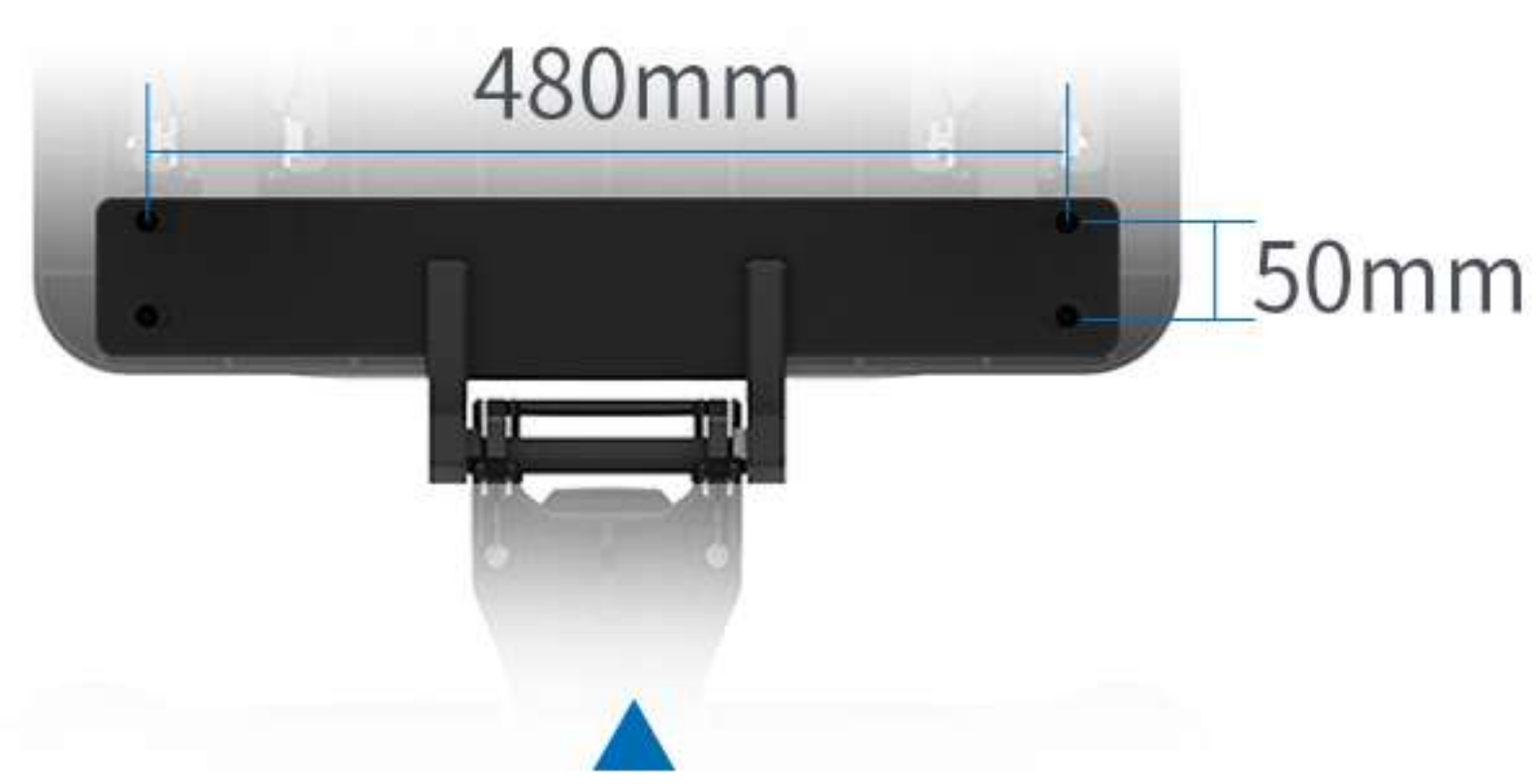

Cart Adaptive Mounting Hole Dimensions



xsto[®] Motorized Platform Cart
Product Parameters



○ Maximum Capacity	300kg (Cargo 200KG + Operator 100KG)	150kg (Cargo 50KG + Operator 100KG)
○ Overall Weight	34kg	31kg
○ Cart Weight	13.6kg	11.6kg
○ Battery Weight	4kg	3kg
○ Battery Capacity	25km	15km
○ Speed On Flat Surface	0~10km/h	0~10km/h
○ Speed On Slope	0~5km/h	0~5km/h
○ Maximum Slope	7°	5°
○ Noise	<65dB	<65dB
○ Protection Level	IP54	IP54

Overall Size

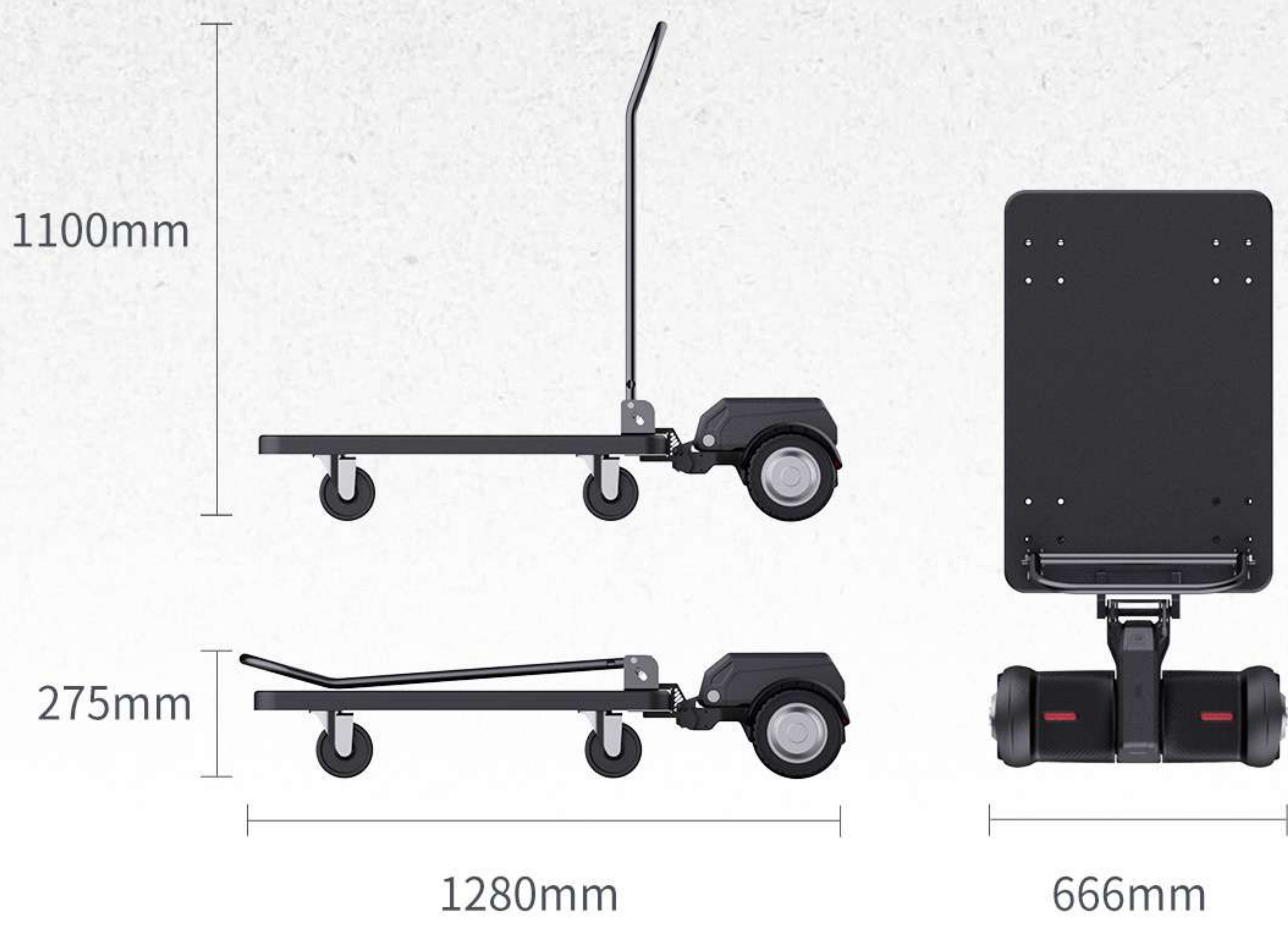

Cart Size



Battery Size



Product Accessories

Cycling Fixture

- Fixture Weight
1.3kg
- Fixture Material
Aluminum Alloy
- Fixture Size
480x997mm



Ease Your Way to Anywhere



XSTO CO., LTD.

+86-760-28207258

info@xsto.net

xstoclimbers.com

· 555 Plant. Ma' an Cun Rd, Cuiheng New District, Zhongshan City, Guangdong, China
· Floor 15, No.1 Building, Beijing-Guangzhou Collaborative Innovation Center,
Kaichuang Avenue, Huangpu District, Guangzhou

