

Electric Moving Cart LFC170F3

- Safe Handling
- Automatic Lifting
- Convenient Vehicle Carrying



Electric Moving Cart LFC170F3

Item Details



Rising
Falling

Lifting Control Handle
Loading Plate Rising/Falling

Forward Fast
Backward Slow



Moving Control Handle
Forward/Backward
High Speed/Low Speed

Safety
Quickly Pull Out/Put Away to
Secure Cargo



Battery
Play And Plug With Auto Connection
Independent Switch,
Display battery level and voltage



Lifting Lead Screw
Ball Screw, More Stable
Rising/Falling for Loading Plate



Auxiliary Moving Wheels
Metal Auxiliary Wheels for
Plane Motion



Auxiliary Ground Support Wheel
Auxiliary Casters for
Easy Movement

Loading Board
Structure with Reinforced
Welding, Alloy Steel Material



Brake Motor
Switch-off Power, Manual Operating



Driving Wheel
Wear-resisting Rubber,
Shockproof Pneumatic Tyre

Technical Parameter

Electric Drive---Mile Range·Speed Capacity

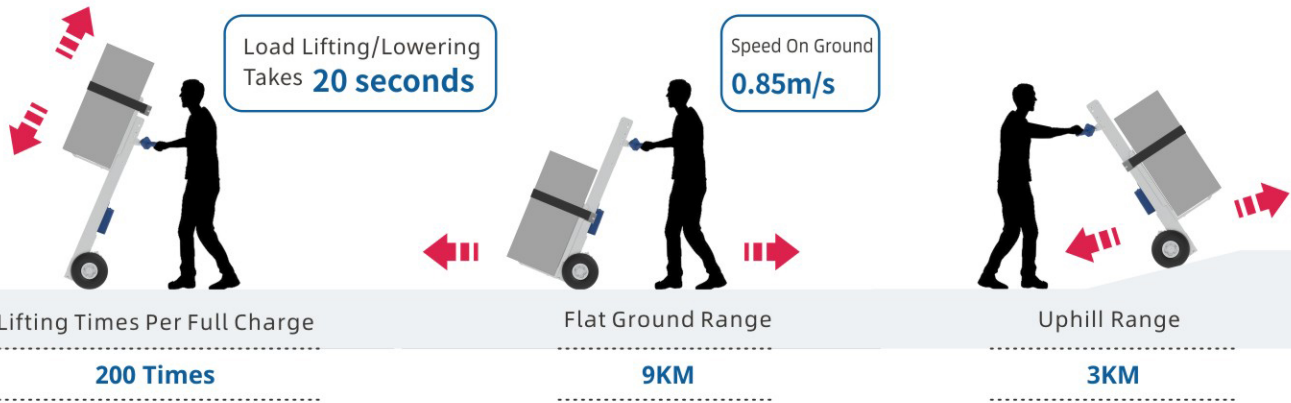

Item Weight

53.8KG



Maximum Capacity

170KG



Max Lifting Height

800MM

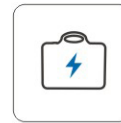

Lithium Battery

48V/10Ah



Maximum Climbing Gradient

15°



Auxiliary Ground Support Wheel

YES



Handrail

Optional

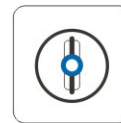

Motor Brake

YES



Output Motor Parameter

48V120W



Driving Motor Output

48V500W



Noise Level

<70dB



Protection Grade

IP33

Electric Moving Cart LFC170F3

Product Size

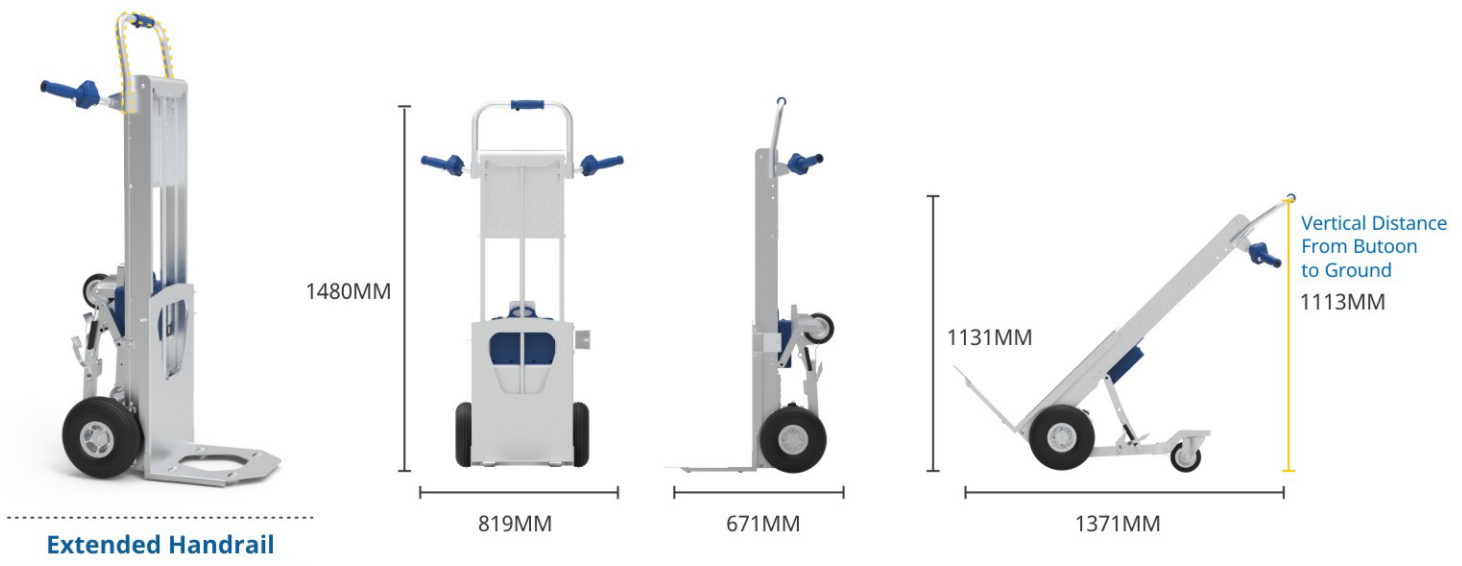
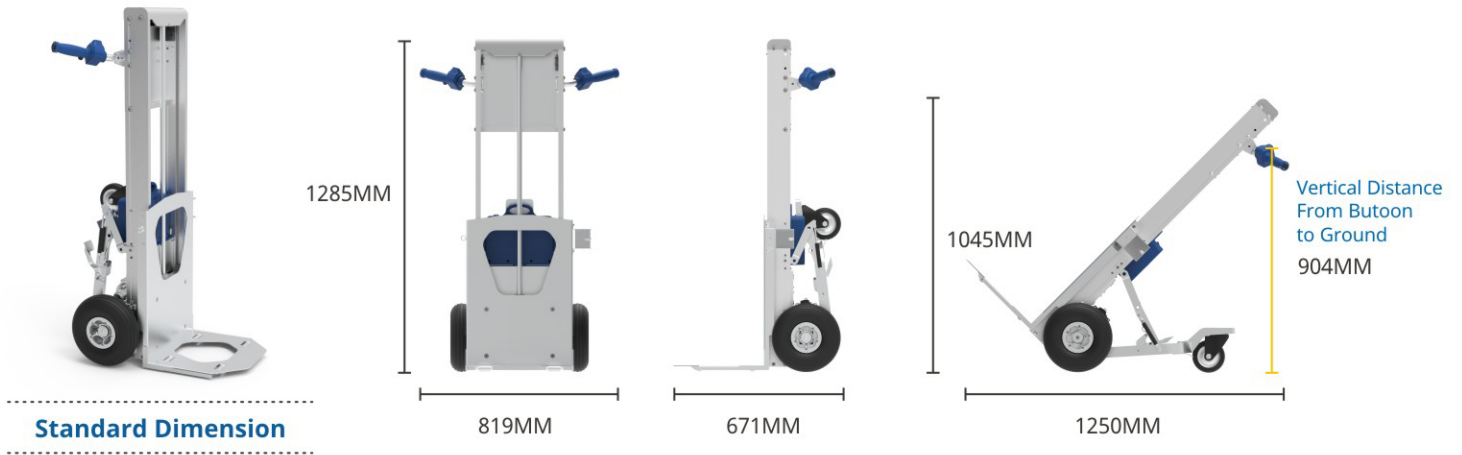

ACCESSORIES



Lithium Battery

Battery Capacity: 48V 10AH

Battery Weight: 3.2KG



Charger

Input: 100V-240V

Output: 54.6V 4A



Safety Strap

Size: 25x1500MM

Self-retracting Ratchet Strap

PRODUCT FUNCTIONS



APPLICATIONS



Warehouse



Factory



Shopping Mall



Hospital

Ease Your Way To Anywhere!



xsto® XSTO CO., LTD.

Website: xstoclimbers.com

Email: info@xsto.net

Tel: +86-760-28207258

Address: Building C, 555 Plant, Ma' an Cun Rd, Cuiheng New District, Zhongshan City, Guangdong, China

